



Move one to four pallets with one versatile solution.

Allows the handling of up to four pallets at a time.

APPLICATIONS

The Single-Double Pallet Handler equipped with long forks allows you to move up to two pallets wide and two deep for a total of up to four pallets in one load. Move loads faster, minimize damage and stay competitive while helping your organization stay green by the realized energy savings. Designed for any application using pallets or containers to transport product. Spreading the forks hydraulically allows handling of up to four pallets. Sideshifting provides added flexibility for aligning forks or pallets in tight areas.

FEATURES

- Superior visibility through and over the frame for damage free handling at all stacking heights
- All steel frame for increased overall durability, eliminating flexing
- Easy access cylinders for quick servicing
- Bolt-on Interchangeable forks for low service cost
- Full-length, fully enclosed wrap around UHMW plastic bearings provide maximum strength and full bearing support, greatly reducing wear on bearing surface
- Inner forks mounted on a chrome pin for greater inner fork stability

OPTIONS

- Various load backrest configuration heights, fork lengths and sections
- Various fork set spreads and opening ranges
- Quick-disconnect lower hooks
- Drop shank forks—forks are lowered relative to the attachment frame
- Non-Sideshifting models available



SINGLE-DOUBLE LONG FORKS

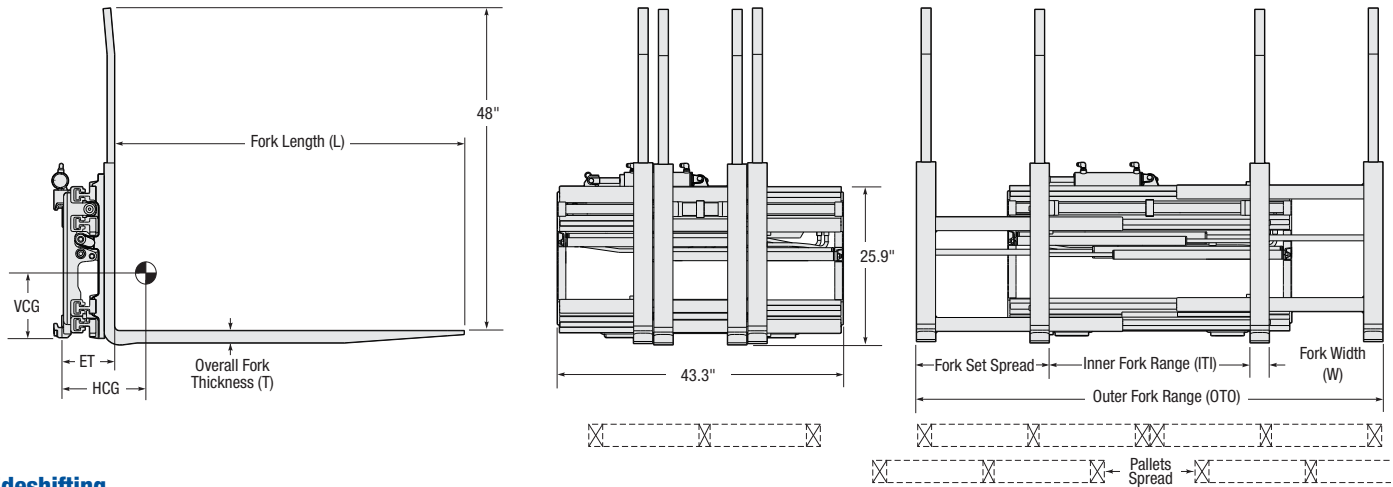

Sideshifting

Capacity @ 48" (1200mm) Load Center		Catalog Order No.	Mounting Class	Min. Truck Carriage Width	Weight		Effective Thickness ET	Horizontal Ctr. Of Gravity HCG	Vertical Center of Gravity VCG	Inner Fork Range ITI	Outer Fork Range OTO	Average Pallet Spread	Fork Set Spread	Fork Size (inches) L x W x T
lbs	kg				lbs	kg								
36" x 36" Beverage Pallets														
2,750	1,250	12G-FQS-A005	II	36.0"	1,365	620	9.1"	16.3"	8.5"	13.0"-32.1"	26.0"-80.1"	20.0"	24.0"	70.9" x 3.1" x 2.0"
2,750	1,250	12G-FQS-B005	III	36.0"	1,630	740	8.9"	16.3"	8.7"	13.0"-32.1"	26.0"-80.1"	20.0"	24.0"	70.9" x 3.1" x 2.0"
3,000	1,500	15G-FQS-B005	III	36.0"	1,490	675	9.3"	17.6"	8.3"	13.0"-32.1"	26.0"-80.1"	20.0"	24.0"	70.9" x 3.1" x 2.4"
48" x 40" Block and GMA Pallets														
2,750	1,250	12G-FQS-A221	II	36.0"	1,475	670	9.1"	20.0"	8.0"	14.6"-28.7"	27.6"-82.7"	15.0"	27.0"	83.9" x 3.1" x 2.0"
2,750	1,250	12G-FQS-B221	III	36.0"	1,470	665	8.9"	20.0"	8.1"	14.6"-28.7"	27.6"-82.7"	15.0"	27.0"	83.9" x 3.1" x 2.0"
3,000	1,500	15G-FQS-B221	III	36.0"	1,620	735	9.3"	21.5"	7.7"	14.6"-28.7"	27.6"-82.7"	15.0"	27.0"	83.9" x 3.1" x 2.4"
48" x 40" GMA Pallets														
2,750	1,250	12G-FQS-A009	II	36.0"	1,470	665	9.1"	20.0"	7.9"	18.9"-31.0"	31.9"-87.0"	19.0"	28.0"	83.9" x 3.1" x 2.0"
2,750	1,250	12G-FQS-B009	III	36.0"	1,470	665	8.9"	20.0"	8.0"	18.9"-31.0"	31.9"-87.0"	19.0"	28.0"	83.9" x 3.1" x 2.0"
3,000	1,500	15G-FQS-B009	III	36.0"	1,620	735	9.3"	21.5"	7.6"	18.9"-31.0"	31.9"-87.0"	19.0"	28.0"	83.9" x 3.1" x 2.4"
44" x 56" Container Pallets														
2,750	1,250	12G-FQS-A013	II	36.0"	1,620	735	9.1"	28.2"	6.8"	13.0"-28.1"	26.0"-80.0"	11.0"	26.0"	107.9" x 3.1" x 2.0"
2,750	1,250	12G-FQS-B013	III	36.0"	1,620	735	8.9"	28.2"	7.0"	13.0"-28.1"	26.0"-80.0"	11.0"	26.0"	107.9" x 3.1" x 2.0"
3,000	1,500	15G-FQS-B013	III	36.0"	1,800	815	9.3"	30.2"	6.5"	13.0"-28.1"	26.0"-80.0"	11.0"	26.0"	107.9" x 3.1" x 2.4"

① This model can handle GMA type stringer and block pallets, including Chep Type III and Mark 55 pallets in both directions. The single-mode fork positioning range is 15.0" to 21.0" in-to-in, or 27.5" to 33.5" out-to-out. Average pallet spread is 8.0" for both pallets. No additional truck auxiliary valves required, beyond the normal two auxiliary valves.

- ▶ Other fork lengths available.
- ▶ Right hand termination standard, left hand termination available at no charge.
- ▶ PLASTIC PALLETS MAY REQUIRE MODIFIED FORK DIMENSIONS.
- ▶ The outer fork tines are .2" higher than the inner fork tines.
- ▶ 8" (200 mm) total sideshift.

SINGLE DOUBLE CONVERSION KIT

Model	Conversion	Catalog Order No.
12G	Class II to III	6072573
12G	Class III to II	6072574

INSTALLATION KIT

Model	Catalog Order No.
Class II	6072233
Class III	6072234

HYDRAULIC FLOW & PRESSURE

Maximum Pressure psi/bar	Min-Rec-Max Function 1	Min-Rec-Max Function 2
	gpm	gpm
2,900/200	1 — 2 — 3	4 — 7 — 7

HYDRAULIC FUNCTIONS

Hydraulic Functions	Truck Auxiliary Valves Required
2	2