



*Rotating forks
can be set in
three positions
for multi-purpose
handling.*



MANUAL TURNAFORK™



Rotating Forks For Both Clamp and Pallet Handling

APPLICATIONS

Cascade's Turnafork with manually operating rotating forks can be used for both clamp and pallet handling. The forks can be set in three positions by simply pulling a spring lock on the fork pivot plate and turning the arm: clamp position, pallet position and the in between 45° position for handling special shaped loads.

The Turnafork is used in a variety of shipping, receiving and order picking applications. When clamp handling, loads may be removed from captive pallets and directly floor loaded in the transporting vehicle, or they may be transferred to a slipsheet or shipping pallet. In the pallet fork position, the Turnafork may be used for handling nearly any type of conventional pallet.

BENEFITS

- **Visibility**—Low profile frame provides excellent visibility over the top of the frame. I-beam arm bar design improves visibility when arms are extended.
- **Rugged, lightweight construction**—High strength, rugged construction combined with low overall clamp weight due to Cascade's unique I-beam arm bar and frame design, aluminum alloy arm bar channels and nylon arm bearings, resulting in high net attachment/lift truck capacities.
- **Fast and energy efficient**—Regenerative hydraulic circuit for faster arm opening speeds with less energy consumption, a particularly valuable benefit for electric trucks.

OPTIONS

- Special arm lengths and widths
- Load Backrests—To provide support for unsecured loads that extend above the frame.
- Quick Change Lower Hooks—Allow the clamp to be installed in a matter of minutes without tools.



Revolving Model

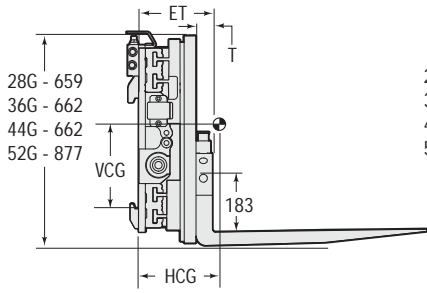

Sideshifting Model

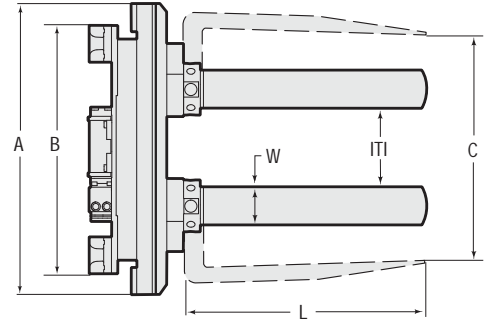
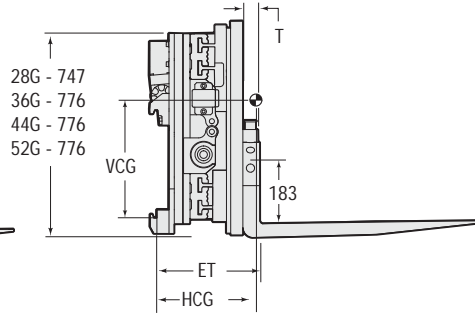

Catalogue Order No.	Capacity @ Load Centre on forks kg @ mm	Capacity @ Load Centre as clamp kg @ mm	Frame width (mm) A	Opening Range between forks (mm) ITI	Opening Range between arms (mm) C	Fork length x section (mm) LxWxT	Minimum Truck Carriage Width (mm) B	Effective thickness (mm) ET	Horizontal Centre of gravity (mm) HCG	Vertical Centre of gravity (mm) VCG	Weight kg	Mounting class ISO 2328
Sideshifting												
28G-TMS-A212	1800@500	1400@500	950	115-1225	560-1675	1000x125x40	835	230	186	—	364	2A
28G-TMS-A213	1800@500	1400@500	950	115-1225	560-1675	1200x125x40	835	230	224	—	380	2A
36G-TMS-A212	2200@500	1800@500	950	115-1235	565-1685	1000x125x40	835	240	196	183	403	2A
36G-TMS-A213	2200@500	1800@500	950	115-1235	565-1685	1200x125x40	835	240	236	174	421	2A
36G-TMS-A312	2200@500	1800@500	1050	110-1325	560-1775	1000x125x40	835	240	192	185	416	2A
36G-TMS-A313	2200@500	1800@500	1050	110-1325	560-1775	1200x125x40	835	240	231	176	433	2A
44G-TMS-A212	2600@500	2200@500	950	115-1235	565-1685	1000x125x45	835	243	196	184	409	2AⓈ
44G-TMS-A213	2600@500	2200@500	950	115-1235	565-1685	1200x125x45	835	243	235	175	427	2AⓈ
44G-TMS-A312	2600@500	2200@500	1050	110-1325	560-1775	1000x125x45	835	243	192	186	422	2AⓈ
44G-TMS-A313	2600@500	2200@500	1050	110-1325	560-1775	1200x125x45	835	243	230	177	439	2AⓈ
52G-TMS-B312	3200@500	2600@500	1050	115-1325	585-1800	1000x150x50	924	277	210	221	567	3A
52G-TMS-B313	3200@500	2600@500	1050	115-1325	585-1800	1200x150x50	924	277	248	211	591	3A
52G-TMS-B512	3200@500	2600@500	1150	110-1420	585-1895	1000x150x50	924	277	206	223	584	3A
52G-TMS-B513	3200@500	2600@500	1150	110-1420	585-1895	1200x150x50	924	277	243	213	607	3A
64G-TMS-B711	3600@600	3200@600	Consult Cascade			1200x150x50	Consult Cascade			3A		
64G-TMS-B712	3600@600	3200@600	Consult Cascade			1200x150x50	Consult Cascade			3A		
Revolving												
28G-TMR-A212	1800@500	1400@500	950	115-1235	560-1675	1000x125x40	813	315	207	237	508	2A
28G-TMR-A213	1800@500	1400@500	950	115-1225	560-1675	1200x125x40	813	315	237	229	523	2A
36G-TMR-A212	2200@500	1800@500	950	115-1235	565-1685	1000x125x45	813	348	225	255	620	2A
36G-TMR-A213	2200@500	1800@500	950	115-1235	565-1685	1200x125x45	813	348	253	247	638	2A
36G-TMR-A312	2200@500	1800@500	1050	100-1330	550-1780	1000x125x45	813	348	225	256	634	2A
36G-TMR-A313	2200@500	1800@500	1050	100-1330	550-1780	1200x125x45	813	348	252	248	651	2A
44G-TMR-A212	2600@500	2200@500	950	110-1260	560-1710	1000x125x45	813	350	227	255	628	2AⓈ
44G-TMR-A213	2600@500	2200@500	950	110-1260	560-1710	1200x125x45	813	350	255	248	646	2AⓈ
44G-TMR-A312	2600@500	2200@500	1050	95-1330	545-1780	1000x125x45	813	350	253	249	656	2AⓈ
44G-TMR-A313	2600@500	2200@500	1050	95-1330	545-1780	1200x125x45	813	350	254	248	650	2AⓈ
52G-TMR-B312	3200@500	2600@500	1050	115-1325	585-1800	1000x150x50	813	410	283	253	738	3A
52G-TMR-B313	3200@500	2600@500	1050	115-1325	585-1800	1200x150x50	813	410	314	244	760	3A
52G-TMR-B512	3200@500	2600@500	1150	110-1420	585-1895	1000x150x50	813	410	281	255	754	3A
52G-TMR-B513	3200@500	2600@500	1150	110-1420	585-1895	1200x150x50	813	410	312	246	777	3A

Ⓢ 44G : Mounting Class 3A available. Consult Cascade for specifications.

- ▶ Hand operated.
- ▶ Frame bumper not included.
- ▶ Hydraulic cylinder operated forks available. Consult Cascade.

▶ G-Series : Lift trucks with auxiliary pressures between 155 and 189 bar max. require low pressure attachments. Lift trucks with auxiliary pressures between 190 and 250 bar max. require high pressure attachments.

HYDRAULIC FUNCTIONS

Model	Hydraulic Functions	Truck Aux. Valves Required
Sideshifting	2	2
Revolving	2	2

HYDRAULIC FLOW AND PRESSURE

Model	Minimum Flow (L/min.)	Recommended Flow (L/min.)	Maximum Flow (L/min.)	Maximum Pressure (bar)
Sideshifting	19	26	38	250
Rotating	19	38	57	160