

## Standard Equipment/Optional Equipment

### Standard Equipment

#### Operator's compartment

- Mast or load side controls
- Suspension mounted cab to absorb shocks and vibration
- Soft rubber mat isolates operator from shocks and vibration
- Storage compartments, pen holders and space for bottles, cans or tools integrated into cab interior
- LCD "comfort" display with keypad log-on, lift height indicator, speedometer, hourmeter, steer wheel position indicator, battery status and service codes
- Very low step height for easy on/off access
- Steering knob

#### Throughput

- Durable polyurethane wheels
- Regenerative electric braking through the drive motor for optimum use of energy
- Battery discharge indicator with lift cutout

### Optional Equipment

#### Operator's compartment

- Alternative cabin widths (900 mm – 1800 mm)
- Rearview mirror module (left/right) on load side or mast side including LED working lights
- LED cabin working light with two step illumination
- Fan on overhead guard included in mirror module
- Steering wheel
- Macrolon cover for overhead guard
- Attachment base for writing pads/ terminals / other equipment
- Radio preparation 12 V/50 W with two speakers and antenna
- Linde LFM data management system
- Overhead guard : 2200 mm height for greater comfort

#### Throughput

- 10 different chassis, 880 mm – 1580 mm to suit every application
- Supplementary lift 750 mm for easy order picking
- Buttons for supplementary lift on load side for easy handling
- Truck prepared for data terminal, printer, scanner installation
- Semi-automatic navigation system
- Different drive and lift motors available

#### Safety

- Automatic reduction in travel speed with platform raised (LSC 3.0)
- All traction and lift functions interlocked through foot switch and sensors, ensuring two handed operation
- Linde curve control for safe cornering
- Side barriers with gas struts and safety interlocks
- Warning light

#### Safety

- Alternative speed reduction and end of aisle stop interlocks
- Aisle Safety Assist for individual safety interlocks for each aisle
- Lift and traction cut outs
- Touchless anti-collision sensor for lifting
- LSC for speed reduction with weight and load dependent speed profiles for lifting and driving; weight measuring sensor
- Load wheel brakes for increased safety in an emergency

#### Mast / Forks

- Different fork lengths
- Carriage for adjustable forks
- Walk on platform
- Pallet clamp
- Mast soft end stops for lifting / lowering

#### Environment

- Mechanical aisle guidance
- Inductive aisle guidance
- Cold store version
- Antistatic guide rollers and wheels



## Modular high level man-up order picker Capacity up to 1200 kg V

Series 5213

### Safety

The V range truck is designed to guarantee the operator's safety in all conditions while driving, lifting and order picking. Its outstanding visibility through and to either side of the mast offers the highest level of security. The low cab step height increases safety, while the 2 integrated touch sensors on the control panel ensure two handed operation. The LSC monitors driving, lifting and steering movements and reduces their performance automatically, if needed.

### Performance

Efficiency and high performance describe the V range order picker. It is capable of picking at heights up to 12000 mm. Its powerful AC drive units combine optimum performance with low energy consumption. Three different driving and lifting options allow the truck to exactly match the application. The tilting barriers increase productivity - the operator can get closer to the rack to pick loads from the back of the pallet.

### Comfort

Entering the cabin of the V range truck and stepping onto the antivibration floor mat gives the operator the feeling of comfortable working from the first second. The wide variety of storage compartments provided by the attachment bar and options means the truck can be equipped for every kind

Linde Material Handling

Linde

of order picking application. No matter whether it is lifting or lowering, with or without load, the cabin of the V range truck always stops gently and precisely.

### Reliability

Our expertise in designing and building material handling equipment is the guarantee that the V model is a truck you can rely on. Thanks to easy maintenance, downtime is reduced and throughput is increased. An active cooling system ensures the maximum availability even in extreme conditions.

### Productivity

The unique modular design concept of the V-modular ensures that each truck can be tailored to match the application precisely in order to maximize its productivity at all times. Based on the latest ergonomic standards, the working environment and the controls allow the operator to maximise throughput.

## Features

#### Modular concept

- Unique modular design allows the perfect specification for each individual application
- Combination of different lift motors, drive motors, chassis, masts, batteries, cabins, etc. to suit every application
- Two voltage variants provide the perfect solution to customers needs: 48V for high performance in medium and heavy duty applications and 24V variant for low to medium duty applications

#### Variety of applications

- Forks mounted on the operator's platform for working with walk-out pallets. Operator is protected by a cage, the pallet is secured by a clamp
- Platform welded onto the operator's compartment for picking bulky goods
- Suppl. lift on operator's platform. Pallet can be raised to most convenient working height for picking



#### High performance with intelligent control systems

- Linde System Control (LSC) gives stepless automatic adjustment of speed depending on steering angle, lift height and load weight (optional)
- Safe cornering with curve speed control as standard
- Aisle safety assist tailored for each aisle in your warehouse, including lift or traction interlocks, speed reduction etc.

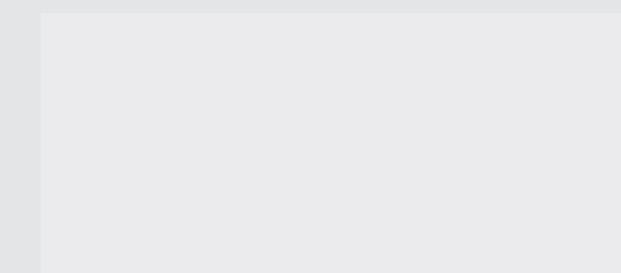

Linde Material Handling GmbH, Postfach 10 01 36, 63701 Aschaffenburg, Germany  
Phone +49.6021.99-0, Fax +49.6021.99-1570, www.linde-mh.com, info@linde-mh.com



#### Operator's compartment

- Specially designed side barriers for optimal order picking
- Deadman pedal hidden under suspension floor mat to avoid trip hazard
- Platform is suspension mounted and has a floor mat designed to absorb shocks and vibration
- Very spacious cabin due to integrated control panels for maximum freedom of movement

#### Control concept

- Controls and integrated display panel are in the operator's field of view
- Standard LCD display gives the driver all necessary information
- Simple, ergonomic controls allow precise operation reducing driver fatigue and increasing throughput
- Simultaneous driving/lifting/lowering
- Safe two-handed operation



#### Safety

- Automatic speed reduction when turning
- All traction and lift functions interlocked through deadman's pedal and 2 handed operation
- Emergency lowering valve under rear cover easily accessible even in the aisle

#### Steering

- Electric steering with defined centre position
- Easy and precise manoeuvring by steering knob (optional steering wheel available)
- Steer angle monitoring ensures safe high-performance driving characteristics



#### Drive and lift

- The powerful and energy-efficient drive and lift units combine optimum performance with low energy consumption and long life
- Latest MOSFET technology
- Rail guidance rollers or inductive wire guidance technology can be fitted to the truck for VNA applications



Subject to modification in the interest of progress. Illustrations and technical details could include options and not binding for actual constructions. All dimensions subject to usual tolerances.

Printed in Germany 131.e: 1.0314.LinDB.K1



# Technical Data according to VDI 2198

Characteristics	LINDE		LINDE		LINDE		LINDE	
	V 24V Example Standard mast <sup>1)</sup>		V 24V Example Triplex mast <sup>1)</sup>		V 48V Example Standard mast <sup>1)</sup>		V 48V Example Triplex mast <sup>1)</sup>	
1.1	Manufacturer							
1.2	Model designation							
1.2a	Series							
1.3	Power unit							
1.4	Operation							
1.5	Load capacity	Q (t)	0.8	0.8	1.2	1.2	1.2	1.2
1.6	Load centre	c (mm)	600	600	400	400	400	400
1.8	Axle centre to fork face	x (mm)	345	405	345	405	345	405
1.9	Wheelbase	y (mm)	1394	1466	1503	1664	1503	1664
2.1	Service weight	(kg)	3185 <sup>2)</sup>	4302 <sup>2)</sup>	4145 <sup>2)</sup>	5498 <sup>2)</sup>	4145 <sup>2)</sup>	5498 <sup>2)</sup>
2.2	Axle load with load, front/rear	(kg)	1272 / 2713 <sup>2)</sup>	1803 / 3299 <sup>2)</sup>	1707 / 3638 <sup>2)</sup>	2289 / 4409 <sup>2)</sup>	1707 / 3638 <sup>2)</sup>	2289 / 4409 <sup>2)</sup>
2.3	Axle load without load, front/rear	(kg)	1814 / 1371 <sup>2)</sup>	2351 / 1951 <sup>2)</sup>	2302 / 1843 <sup>2)</sup>	2870 / 2628 <sup>2)</sup>	2302 / 1843 <sup>2)</sup>	2870 / 2628 <sup>2)</sup>
3.1	Tyres rubber, SE, pneumatic, polyurethane		Polyurethane	Polyurethane	Polyurethane	Polyurethane	Polyurethane	Polyurethane
3.2	Tyre size, front		Ø 360 x 130	Ø 360 x 130	Ø 360 x 130	Ø 360 x 130	Ø 360 x 130	Ø 360 x 130
3.3	Tyre size, rear		Ø 180 x 156	Ø 180 x 156	Ø 180 x 156	Ø 180 x 156	Ø 180 x 156	Ø 180 x 156
3.5	Wheels, number front/rear (x = driven)		1x / 2	1x / 2	1x / 2	1x / 2	1x / 2	1x / 2
3.6	Track width, front	b10 (mm)	0	0	0	0	0	0
3.7	Track width, rear	b11 (mm)	695	895	995	1394	695	895
4.2	Height of mast, lowered	h1 (mm)	2900	3400	3900	4500	2900	3400
4.3	Free lift	h2 (mm)	-	2750	-	3850	-	2750
4.4	Lift	h3 (mm)	4125	7160	5725	10160	4125	7160
4.5	Height of mast, extended	h4 (mm)	6415	9450	8015	12450	6415	9450
4.7	Height of overhead guard (cabin)	h6 (mm)	2290	2290	2290	2290	2290	2290
4.8	Height of seat/stand on platform	h7 (mm)	240	240	240	240	240	240
4.11	Supplementary lift	h9 (mm)	740	740	740	740	740	740
4.14	Platform height, raised	h12 (mm)	4365	7400	5965	10400	4365	7400
4.15	Height, lowered	h13 (mm)	65	65	65	65	65	65
4.19	Overall length	l1 (mm)	3277	3536	3018	3294	3277	3536
4.20	Length to fork face	l2 (mm)	2077	2336	2218	2494	2077	2336
4.21	Overall width	b1/b2 (mm)	880 / 880	1080 / 1080	1080 / 1180	1080 / 1580	880 / 880	1080 / 1080
4.22	Fork dimensions	s/e/l (mm)	55 x 120 x 1200	55 x 120 x 1200	55 x 120 x 800	55 x 120 x 800	55 x 120 x 1200	55 x 120 x 1200
4.23	Fork carriage to ISO 2328, class/type A, B		no	no	no	no	no	no
4.24	Width of fork carriage	b3 (mm)	660	660	740	740	660	660
4.25	Fork spread, min/max	b5 (mm)	560 / 560	560 / 560	640 / 640	640 / 640	560 / 560	560 / 560
4.27	Width over side guide rollers	b6 (mm)	-	1275	1375	1815	-	1275
4.31	Ground clearance, below mast	m1 (mm)	50	50	50	50	50	50
4.32	Ground clearance, centre of wheelbase	m2 (mm)	50	50	50	50	50	50
4.34	Aisle width with pallet 800 x 1200 along forks	As1 (mm)	-	1320	1380	1820	-	1320
4.35	Turning radius	Wa (mm)	1732	2034	1873	2089	1732	2034
4.42	End aisle width, with/without load	Au (mm)	3528	3888	3866	4135	3528	3888
5.1	Travel speed, with/without load	(km/h)	9 / 9	10 / 10	11 / 11	13 / 13	9 / 9	10 / 10
5.2	Lifting speed, with/without load	(m/s)	0.28 / 0.3	0.23 / 0.28	0.36 / 0.36 (0.4 / 0.4) <sup>3)</sup>	0.4 / 0.32	0.28 / 0.3	0.23 / 0.28
5.3	Lowering speed, with/without load	(m/s)	0.28 / 0.28	0.28 / 0.28	0.32 / 0.32 (0.35 / 0.35) <sup>3)</sup>	0.35 / 0.35	0.28 / 0.28	0.28 / 0.28
5.9	Acceleration time, with/without load	(s)	8.0 / 8.0	8.0 / 8.0	8.0 / 8.0	8.0 / 8.0	8.0 / 8.0	8.0 / 8.0
5.10	Service brake		Regenerative/Mechanic	Regenerative/Mechanic	Regenerative/Mechanic	Regenerative/Mechanic	Regenerative/Mechanic	Regenerative/Mechanic
6.1	Drive motor, 60 minute rating	(kW)	4.5	4.5	6.5	6.5	4.5	4.5
6.2	Lift motor, rating at S3 15%	(kW)	7.6	7.6	11.5	13	7.6	7.6
6.4	Battery voltage/rated capacity (Sh)	(V/Ah)	24 / 840	24 / 1120	48 / 620	48 / 930	24 / 840	24 / 1120
6.5	Battery weight (± 5%)	(kg)	687	883	933	1309	687	883
8.1	Type of drive control		Microprocessor	Microprocessor	Microprocessor	Microprocessor	Microprocessor	Microprocessor
8.4	Noise level at operator's ear	(dB(A))	64	64	64	64	64	64

1) Exemplary configuration based on a modular trucksystem. Please contact your local sales department for an individual truck configuration.  
 2) Figures with battery, see line 6.4/6.5.  
 3) Figures in parenthesis for optional „Heavy“

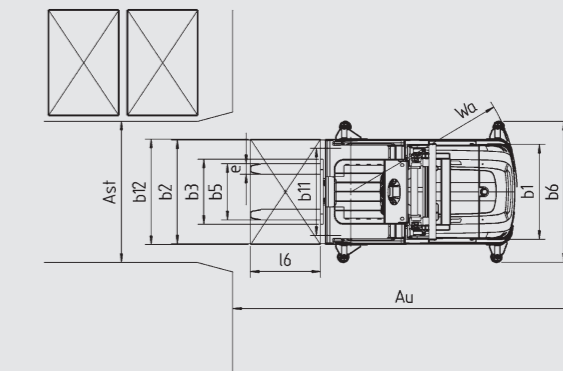
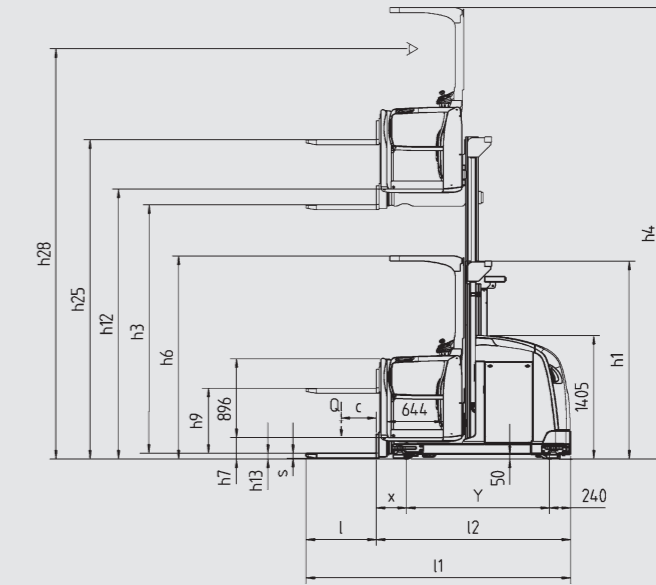

Telescopic mast with supplementary lift

Height of mast, lowered (h1)	Total lift height from ground h25 (h3+h9+h13)	Total lift height h24 (h3+h9)	Lift height w/o supplementary lift h3	Supplementary lift h9	Platform height h12 (h3+h7)	Picking height h28 (h12+1600)	Extended height h4
2250	3630	3565	2825	740	3065	4665	5115
2450	4030	3965	3225	740	3465	5065	5515
2900	4930	4865	4125	740	4365	5965	6415
3400	5930	5865	5125	740	5365	6965	7415
3900	6530	6465	5725	740	5965	7565	8015
4400	7530	7465	6725	740	6965	8565	9015
4900	8530	8465	7725	740	7965	9565	10015
5400	9330	9265	8525	740	8765	10365	10815

Triplex mast with supplementary lift

Height of mast, lowered (h1)	Total lift height from ground h25 (h3+h9+h13)	Total lift height h24 (h3+h9)	Lift height w/o supplementary lift h3	Free lift h2	Supplementary lift h9	Platform height h12 (h3+h7)	Picking height h28 (h12+1600)	Extended height h4
2250	5215	5150	4410	1600	740	4650	6250	6700
2450	5815	5750	5010	1800	740	5250	6850	7300
2900	7165	7100	6360	2250	740	6600	8200	8650
3400	7965	7900	7160	2750	740	7400	9000	9450
3900	9465	9400	8660	3250	740	8900	10500	10950
4500	10965	10900	10160	3850	740	10400	12000	12450